

Constant Air Volume Regulator

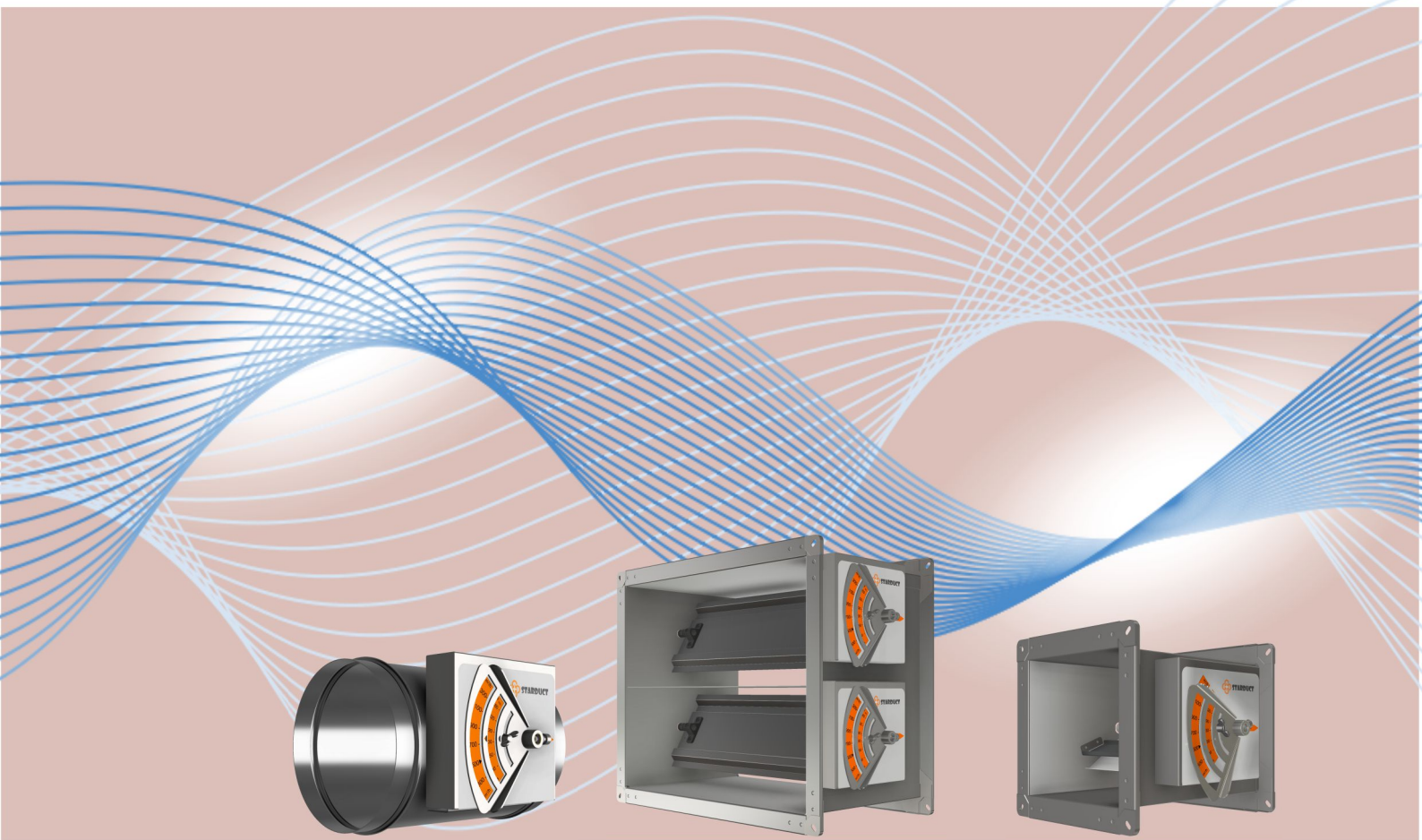

CAV terminal units



CATALOGUE 2024

CHÚNG TÔI

BẢN

SỰ VƯỢT TRỘI

STARDUCT CERTIFIED MANUFACTURER



With nearly 20 years of experience in manufacturing supplement and supporting systems for M.E.P and HVAC, Star Asia Jsc. has been supplying many major heavy industrial, commercial and residential projects with its Starduct products and service.

Starduct VAV terminal units of Star Asia are results of carefully researching, testing and manufacturing in a long period of time. With complex requirements in terms of technical standards and accuracy in operation, these products require a close combination of professional design engineers, technical staff and experienced workers. . Therefore, VAV boxes are not only products but also the pride of our company.

PRODUCTION SYSTEM AND PROCESS OF STAR ASIA

In order to meet the high technical requirements of products, Star Asia has focused on long-term investment in research and development (R&D), design engineers are directly involved in manufacturing product, quality inspection and testing.

Towards the international market, our VAV terminal units are processed, manufactured, assembled and quality controlled on the most modern machine tools and testing equipment

To ensure reliability and accuracy according to specifications, all batches of VAV products are tested prior to shipment.

APPLICABLE STANDARDS

Meeting technical requirements of national and international standards is a direction throughout Star Asia's activities. In designing, manufacturing and testing, Star Asia references and bases on the highest standards in the industry as a basis such as AMCA, ASTM, ASHRAE, ISO, AHRI, TCVN...

Star Asia Jsc. is the member of AMCA (Air Movement and Control Association), ASHRAE (American Society of Heating, Refrigerating and Air-Conditioning Engineers), AHRI (Air-Conditioning, Heating, and Refrigeration Institute), so we are usually receiving relevant updates from these organizations, so that it can be professionally applied to our products.

STARDUCT là thành viên của AMCA Quốc tế
(Hiệp hội Lưu chuyển và Kiểm soát Không khí)





DAS CERTIFICATION

Quality Management System Certificate of Approval

This is to certify that the QMS of

STARDUCT MECHANICAL FACTORY

(belongs to STAR ASIA TECHNOLOGICAL INVESTMENT JOINT STOCK COMPANY)
Phung Town industrial park, Dan Phuong district, Hanoi City, Vietnam

Has been assessed and found to meet the requirements of

ISO 9001:2015

This certificate is valid for the following scope of operations:

Manufacture and supply of air grilles, air dampers, air ducts, cable tray, cable trunking, cable ladder and HVAC accessories, solar battery brackets

Authorised by:



Nguyen Huong Giang
Director

Date of Certificate Issue: 1st February 2024

Certificate Valid Until: 31st January 2027

EA code: 25.99. Recertification audit before 1st November 2026. Certified since 1st February 2018.

This certificate is the property of DAS Vietnam Certification Co.,Ltd and remains valid subject to satisfactory annual Surveillance audits.

DAS Vietnam Certification Co.,Ltd

6th Floor, 34JSC office building,
Lane 164 Khuat Duy Tien street,
Thanh Xuan district, Hanoi City, Vietnam.
Tel: +(84) 024.37763177 – 024.35539135
Email: dasinfo@dasvietnam.com
Web: www.das.com.vn

Certificate Number: NVQV 17299



VICAS-009 QMS

Constant Air Volume Regulator CAV terminal units



Application :

- CONSTANT FLOW CAV controllers of the precise supply air or extract air flow control in constant air volume systems
- Mechanical self-powered volume flow control without external power supply
- Simplified project handling with orders based on nominal size Volume flow rate setpoint can be set on external scale
- Switching between $q_{v,min}$ and $q_{v,max}$ using optional actuator

Product Features :

CONSTANT FLOW CAV are self-powered volume flow controllers for the control of supply air or extract air in constant air volume systems

- Volume flow rate can be set using an external scale, no tools required
- High control accuracy
- No on-site test measurements required for commissioning
- Suitable for airflow velocities of up to 12 m/s
- Any installation orientation; maintenance-free
- Casing air leakage to EN 1751, class C

Optional equipment and accessories

- Acoustic cladding for the reduction of case-radiated noise
- Secondary silencer for the reduction of air-regenerated noise
- Hot water heat exchanger and electric air heater for reheating the airflow
- Actuator for switching between setpoint values

RECTANGULAR CAV



SPECIFICATIONS

Application

- Rectangular EXCONTROL CONSTANTFLOW CAV controllers of Type EN for supply air / extract air volume flow control in constant air volume systems
- Mechanical self-powered volume flow control without external power supply
- Simplified project handling with orders based on nominal size

Special characteristics

- Volume flow rate set point can be set from outside by rotary Cam plate
- High control accuracy of the set volume flow
- Any installation orientation
- Correct operation even under un-favourable up stream conditions
- Visual display of damper blade position for operating point optimisation

Nominal sizes

- 19 nominal sizes from 200 × 100 – 600 × 600 mm

Construction

- Galvanised sheet steel
- Powder-coated.

Parts and characteristics

- Ready-to-commission controller
- Damper blade with low-friction bearings
- Bellows that acts as an oscillation damper
- Cam plate with leaf spring

- Rotary knob with pointer and scale for setting the volume flow setpoint value
- Aerodynamic functional testing of each unit on a special test rig prior to shipping
- Visual display of damper blade position for operating point optimisation

Galvanised sheet steel construction

- Casing and damper blade made of galvanised sheet steel
- Leaf spring made of stainless steel
- Polyurethane bellows
- Cam plate and adjusting unit made of galvanised sheet steel

Standards and guidelines

- Casing air leakage tested to EN 1751, class C

Maintenance

- Maintenance-free as construction and materials are not subject to wear

Technical data

Nominal sizes	200 × 100 – 600 × 600 mm
Volume flow rate range	39 – 3500 l/s or 140 – 12600 m ³ /h
Volume flow rate control range	Approx. 25 to 100 % of the nominal volume flow rate
Scale accuracy	± 4 %
Minimum differential pressure	50 Pa
Maximum differential pressure	1000 Pa
Operating temperature	10 to 50 °C

CAV H < 300 - Single Section

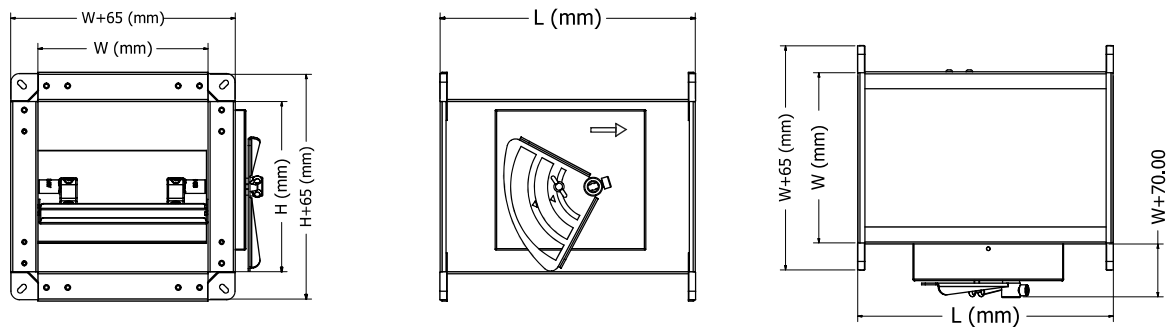

H > 300 - Multiple Section

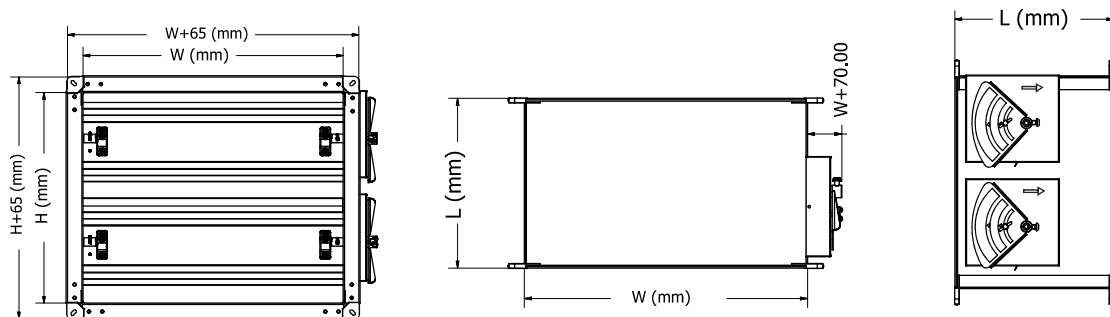

Kích thước W x H (mm)	L (mm)	H (mm)	Ø (mm) Tiết diện tròn tương đương	Kích thước W x H (mm)	L (mm)	H (mm)	Ø (mm) Tiết diện tròn tương đương
200 x 100	300	100	133	600 x 250	300	250	353
300 x 100	300	100	150	500 x 300	300	300	375
200 x 150	300	150	172	600 x 300	300	300	400
300 x 150	300	150	200	400 x 400	300	400	400
200 x 200	300	200	200	500 x 400	300	400	444
300 x 200	300	200	240	600 x 400	300	400	480
500 x 200	300	200	286	500 x 500	300	500	500
400 x 250	300	250	308	600 x 500	300	500	546
500 x 250	300	250	333	600 x 600	300	600	600

CAV Operating Range

SPECIFICATION

Vk min @ 2.0 m/s - Vk max @ 12 m/s
P@ 50 - 1000 Pa. Temp. @ 10-80° C

Air Flow Recommendation

Kích thước W x H (mm)	Lưu lượng Q [m3/h]		Δp min [Pa]	Kích thước W x H (mm)	Lưu lượng Q [m3/h]		Δp min [Pa]
200x100	Min	200	70<P<1000	600x250	Min	1300	91<P<1000
	Max	525	158<P<1000		Max	4000	186<P<1000
300x100	Min	300	90<P<1000	500x300	Min	1350	91<P<1000
	Max	1000	200<P<1000		Max	4000	175<P<1000
200x150	Min	300	84<P<1000	600x300	Min	1620	145<P<1000
	Max	1050	199<P<1000		Max	4800	130<P<1000
300x150	Min	425	80<P<1000	400x400	Min	1440	104<P<1000
	Max	1350	186<P<1000		Max	5800	130<P<1000
200x200	Min	375	75<P<1000	500x400	Min	2100	112<P<1000
	Max	1100	175<P<1000		Max	6575	130<P<1000
300x200	Min	580	37<P<1000	600x400	Min	2100	85<P<1000
	Max	1600	130<P<1000		Max	6400	130<P<1000
500x200	Min	900	79<P<1000	500x500	Min	2050	87<P<1000
	Max	2700	158<P<1000		Max	6500	130<P<1000
400x250	Min	900	86<P<1000	600x500	Min	2700	76<P<1000
	Max	2800	200<P<1000		Max	8400	130<P<1000
500x250	Min	725	77<P<1000	600x600	Min	2775	82<P<1000
	Max	3400	199<P<1000		Max	9050	130<P<1000

 On request other sizes available

Sound Power Level

Kích thước W x H (mm)	Lưu lượng Q [m3/h]		Lw [dB]				Kích thước W x H (mm)	Lưu lượng Q [m3/h]		Lw [dB]			
			150 Pa	300 Pa	450 Pa	600 Pa				150 Pa	300 Pa	450 Pa	600 Pa
200x100	Min	200	50	57	61	64	600x250	Min	1300	54	61	65	68
	Max	525	55	61	65	68		Max	4000	58	64	68	71
300x100	Min	300	49	57	60	64	500x300	Min	1350	54	61	65	68
	Max	1000	57	63	66	69		Max	4000	58	64	68	71
200x150	Min	300	50	57	61	64	600x300	Min	1620	55	62	66	69
	Max	1050	58	64	67	70		Max	4800	59	65	69	72
300x150	Min	425	50	57	61	64	400x400	Min	1440	54	61	65	68
	Max	1350	56	63	66	69		Max	5800	62	68	71	74
200x200	Min	375	49	57	61	64	500x400	Min	2100	55	65	66	69
	Max	1100	55	62	65	68		Max	6575	62	68	72	74
300x200	Min	580	50	57	61	64	600x400	Min	2100	58	65	69	72
	Max	1600	55	61	65	67		Max	6400	61	68	71	74
500x200	Min	900	52	59	63	66	500x500	Min	2050	57	65	68	71
	Max	2700	56	62	66	69		Max	6500	61	68	71	74
400x250	Min	900	52	59	63	66	600x500	Min	2700	59	66	70	73
	Max	2800	57	64	67	70		Max	8400	64	70	74	77
500x250	Min	725	53	60	64	67	600x600	Min	2775	60	67	71	74
	Max	3400	58	64	68	70		Max	9050	64	70	74	77

Installation and commissioning

- Any installation orientation (from H = 500 mm, the horizontal air duct must be installed so that the operating side is positioned to the side (right / left) or below)
- Equipotential bonding to be provided by others
- Volume flow rate setpoint can be set from outside by rotary knob
- Loosen and lock the rotary knob with hexagonal socket screw
- No repeat measurements or adjustments required during commissioning
- For constructions with acoustic cladding, ducts on the room side should have cladding up to the acoustic cladding of the controller

Upstream conditions

The volume flow rate accuracy Δq_v applies to straight upstream. Bends, junctions or a narrowing or widening of the duct cause turbulence that may affect measurement. Duct connections, e.g. branches off the main duct, must comply with EN 1505. Free air intake only with a straight duct section of 1.5B or 1.5H upstream.

Space required for commissioning and maintenance

Sufficient space must be clear near to allow for commissioning and maintenance. If necessary, inspection openings of sufficient size are required.

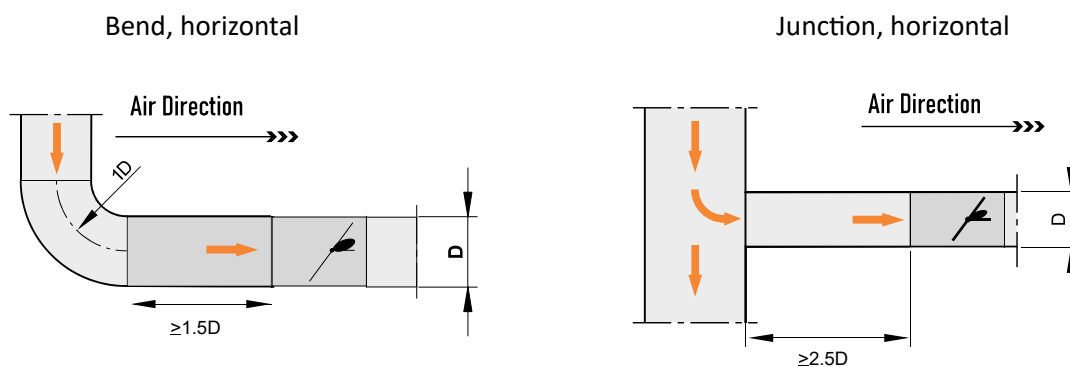

The stated volume flow rate accuracy Δq_v can only be achieved with a straight duct section of at least 1.5D upstream between any bend and the controller.

A junction causes strong turbulence. The stated volume flow rate accuracy Δq_v can only be achieved with a straight duct section of at least 2.5D upstream. If there is no straight upstream section at all, the control will not be stable, even with a perforated plate.

■ ORDERING CODE : S-CAV(R) / S-CAV(RS) - (W mm x H mm)

- S-CAV(R) : Rectangular CAV, without insulation cladding
- S-CAV (RS) : Rectangular CAV, with insulation cladding
- W/H : Dimension step min at 50mm

ROUND CAV

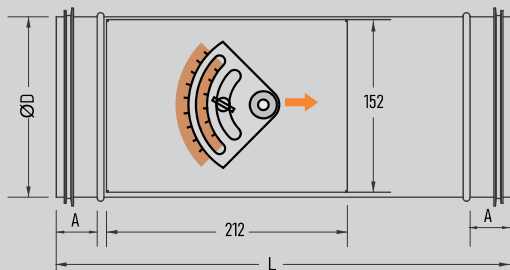

SPECIFICATION TEXT

Application

- Round CONTROL CONSTANT FLOW CAV controllers of Type EN for supply air / extract air volume flow control in constant air volume systems
- Mechanical self-powered volume flow control without external power supply
- Simplified project handling with orders based on nominal size

Special characteristics

- Volume flow rate set point can be set from outside by rotary Cam plate
- High control accuracy of the set volume flow
- Any installation orientation
- Correct operation even under un-favourable up stream conditions
- Visual display of damper blade position for operating point optimisation

Nominal sizes

- Ø80 to Ø400 (mm)

Construction

- Galvanised sheet steel
- Powder-coated.

Parts and characteristics

- Ready-to-commission controller
- Damper blade with low-friction bearings
- Bellows that acts as an oscillation damper
- Cam plate with leaf spring

- Rotary knob with pointer and scale for setting the volume flow setpoint value
- Aerodynamic functional testing of each unit on a special test rig prior to shipping
- Visual display of damper blade position for operating point optimisation

Galvanised sheet steel construction

- Casing and damper blade made of galvanised sheet steel
- Leaf spring made of stainless steel
- Polyurethane bellows
- Cam plate and adjusting unit made of galvanised sheet steel

Standards and guidelines

- Casing air leakage tested to EN 1751, class C

Maintenance

- Maintenance-free as construction and materials are not subject to wear

DIMENSION

■ S-CAV - CAV without insulation cladding

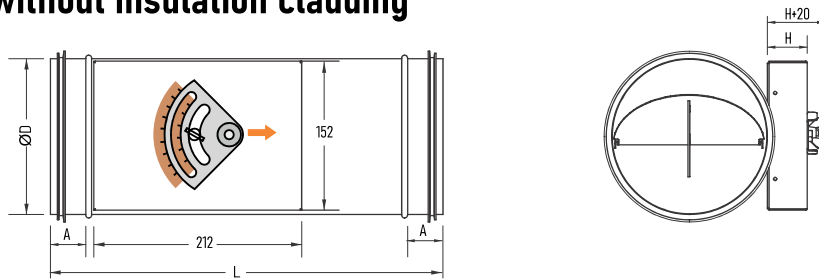

Nominal diameter	D		L	A	Weight
	mm		mm	mm	kg
80	79		300	25	1.4
100	99		300	25	1.8
125	124		300	25	2.0
160	159		300	25	2.5
200	199		300	25	3.0
250	249		400	25	3.5
315	314		400	25	4.8
400	399		400	25	5.7

■ S-CAV(S) - CAV with insulation cladding

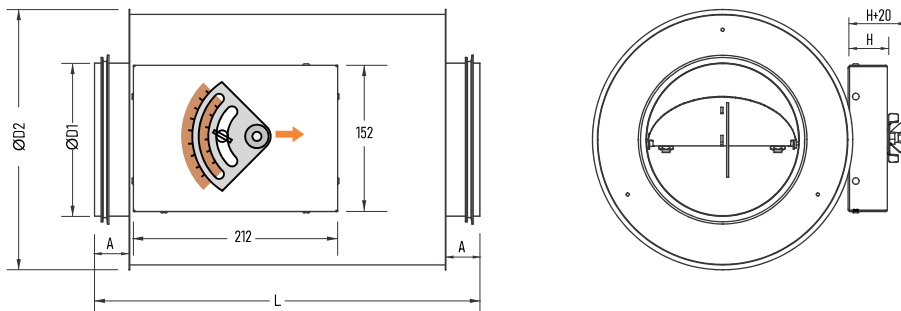

Nominal diameter	D1	D2	L	A	Weight
	mm	mm	mm	mm	kg
80	79	181	300	25	2.2
100	99	200	300	25	3.6
125	124	220	300	25	4.0
160	159	262	300	25	5.0
200	199	300	300	25	6.0
250	249	356	400	25	7.3
315	314	418	400	25	9.8
400	399	500	400	25	11.8

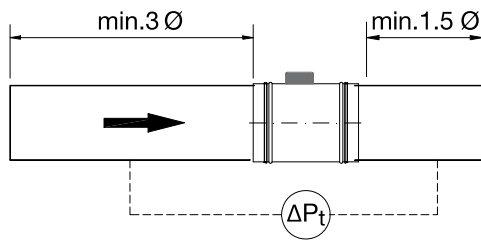
PRODUCT DATA SHEET

CAV Operating Range

Vk min @ 2.0 m/s - Vk max @ 12 m/s
 P@ 50 - 1000 Pa. Temp. @ 10-80° C

Air Flow Recommendation

Ø (mm)	Q (m ³ /h)		ΔPt min (Pa)	Ø (mm)	Q (m ³ /h)		ΔPt min (Pa)
80	Qmin	40	50 <P< 1000	250	Qmin	450	50 <P< 1000
	Qmax	162	110 <P< 1000		Qmax	1200	135 <P< 1000
100	Qmin	100	50 <P< 1000	315	Qmin	700	50 <P< 1000
	Qmax	250	110 <P< 1000		Qmax	2100	220 <P< 1000
125	Qmin	100	50 <P< 1000	355	Qmin	900	50 <P< 1000
	Qmax	350	80 <P< 1000		Qmax	2600	220 <P< 1000
160	Qmin	180	50 <P< 1000	400	Qmin	1000	50 <P< 1000
	Qmax	600	100 <P< 1000		Qmax	3400	220 <P< 1000
200	Qmin	250	50 <P< 1000				
	Qmax	900	125 <P< 1000				

 On request other sizes available

Sound Power Level

Ø (mm)	Q (m ³ /h)	Lw (dB)			Ø (mm)	Q (m ³ /h)	Lw (dB)		
		100 Pa	250 Pa	500 Pa			100 Pa	250 Pa	500 Pa
80	40	32	50	53	250	450	47	59	65
	75	42	54	58		700	49	59	66
	144	48	58	60		1060	51	59	67
	162	50	62	63		1325	52	61	67
100	70	43	50	55	315	700	48	60	66
	110	46	54	60		1120	50	59	67
	170	49	58	64		1680	54	60	67
125	210	50	60	65	355	2100	57	62	67
	110	44	51	56		890	49	61	67
	175	47	55	61		1425	50	61	66
	265	49	58	65		2150	56	62	68
160	330	51	60	66	400	2600	61	64	70
	180	45	54	60		1130	50	62	68
	290	48	57	63		1800	51	61	66
	435	49	58	65		2700	61	63	68
200	540	51	59	66		3400	65	66	71
	280	46	57	64					
	450	48	59	66					
	680	50	59	67					
	850	51	59	67					



Installation and commissioning

- Any installation orientation (from H = 500 mm, the horizontal air duct must be installed so that the operating side is positioned to the side (right / left) or below)
- Equipotential bonding to be provided by others
- Volume flow rate setpoint can be set from outside by rotary knob
- Loosen and lock the rotary knob with hexagonal socket screw
- No repeat measurements or adjustments required during commissioning
- For constructions with acoustic cladding, ducts on the room side should have cladding up to the acoustic cladding of the controller

Upstream conditions

The volume flow rate accuracy Δq_v applies to straight upstream. Bends, junctions or a narrowing or widening of the duct cause turbulence that may affect measurement. Duct connections, e.g. branches off the main duct, must comply with EN 1505. Free air intake only with a straight duct section of 1.5B or 1.5H upstream.

Space required for commissioning and maintenance

Sufficient space must be clear near to allow for commissioning and maintenance. If necessary, inspection openings of sufficient size are required.

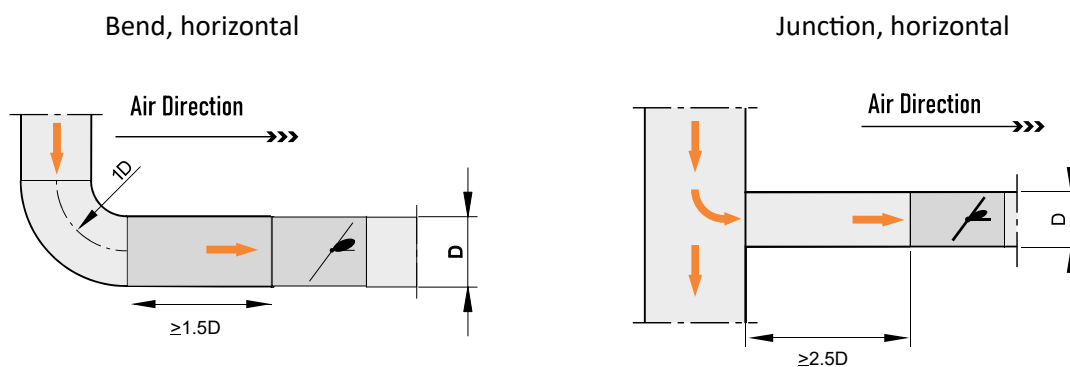

The stated volume flow rate accuracy Δq_v can only be achieved with a straight duct section of at least 1.5D upstream between any bend and the controller.

A junction causes strong turbulence. The stated volume flow rate accuracy Δq_v can only be achieved with a straight duct section of at least 2.5D upstream. If there is no straight upstream section at all, the control will not be stable, even with a perforated plate.

■ ORDERING CODE : S-CAV / S-CAV(S) - DN

- S-CAV : Round CAV, without insulation cladding
- S-CAV(S) : Round CAV, with insulation cladding
- DN = Diameter : 80/100/125/160/200/250/315/400

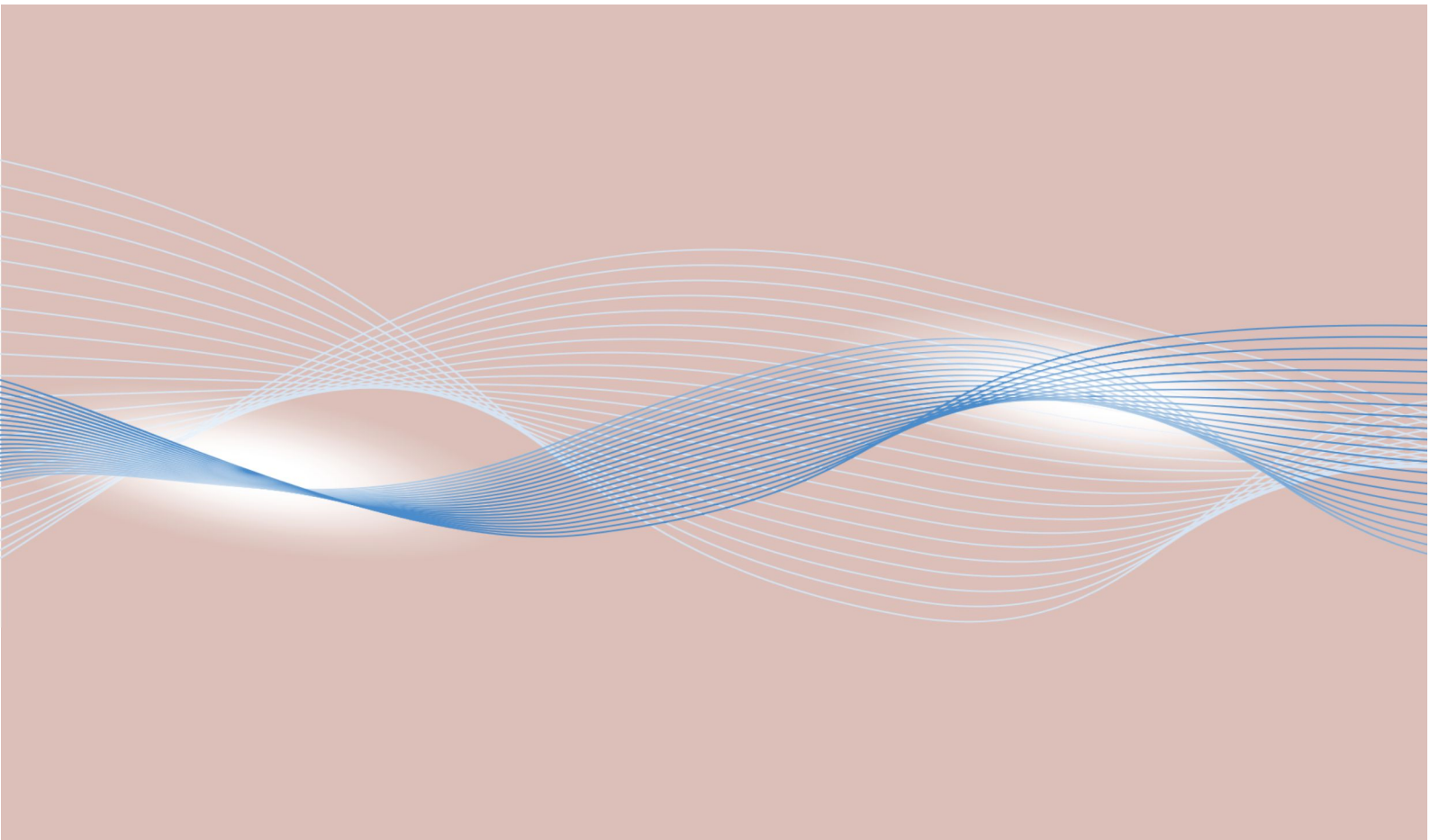

CÔNG TY CP ĐẦU TƯ CÔNG NGHỆ NGÔI SAO CHÂU Á
NHÀ MÁY CƠ KHÍ STARDUCT

Lô C3-C4 khu Công Nghiệp thi trấn Phùng
Đan Phượng - Hà Nội - Việt Nam
ĐT: 024 3514 7999 - Email: nsca@nsca.vn